

S
S
E
H
N
S

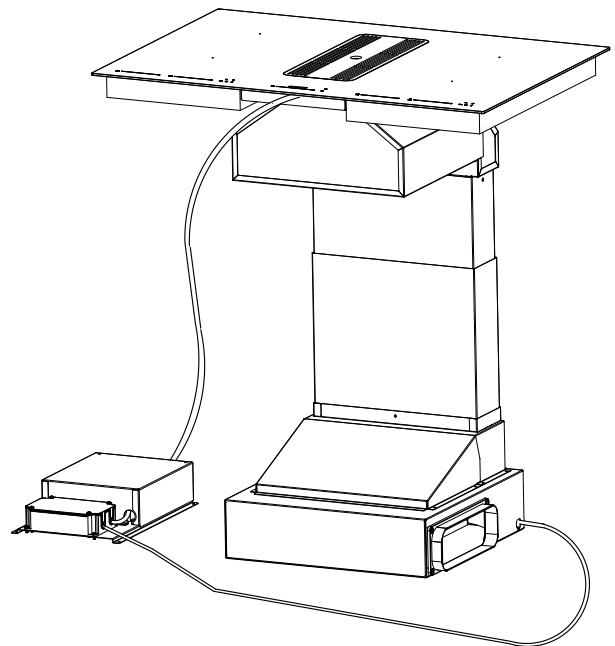

Sirius

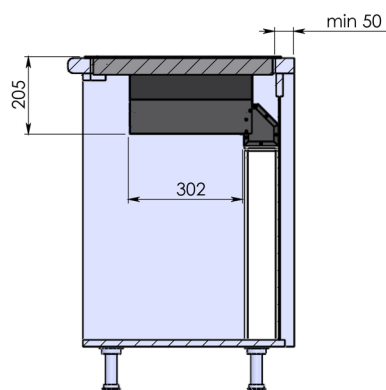
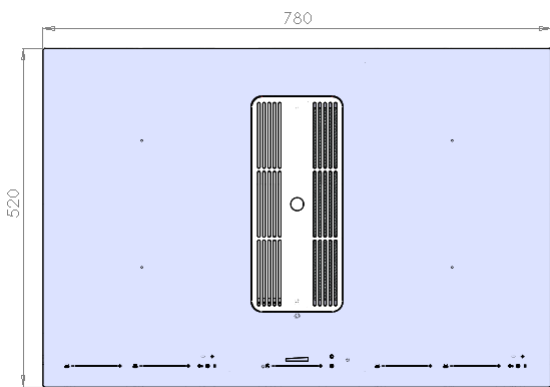

TECHNOLOGY

- . Induction G5
- . Black bevel edge
- . Automatic heat-up function
- . Safety lock
- . Timer function
- . Over-heating protection
- . Operating time limitation
- . Keep warm function
- . Pause function and recall
- . Bridge function
- . Fully Touch Controls
- . Booster function on all zones
- . Cooking output
- . 4 zones (SH3-SH1):
184x220mm
2,1 KW P: 3,7 KW
- . 3 zones (SH2):
184x220m
2,1 KW P: 3,7 KW
- . Total Output: 7400 W
- . Electric rating: 220-240 W
(50-60 Hz)



SDDH3+SEM10

	Q [m3/h]	db [A]	V [m/s]
1°	220	54	3
2°	286	59	4
3°	381	63	5
4°	535	68	7

EEI **B**

SDDH3+SEM12

	Q [m3/h]	db [A]	V [m/s]
1°	286	60	4
2°	374	62	5
3°	497	67	7
4°	655	72	9

EEI **B**



INNOVATION INDUCTION WITH INTEGRATED DOWNDRAFT

The taste and the charm of an innovative product where creativity, elegance and purity of design are inimitable ingredients in a new concept of ventilation between cooktop and integrated Downdraft with LED lighting.

An unique system where the control panel integrated in the hob gives easy functionality to the product and adds personality to your kitchen.





DOWNDRAFT TECHNICAL DATA:

- Motor:** 1000 m3/h (not included)
Available in external motor also
- Lighting:** 1x5 W LED strip
- Control panel:** Touch Control 4 speeds on the Induction Hob
- Filter:** anodized aluminium (4+1)
- Stainless steel:** AISI 304

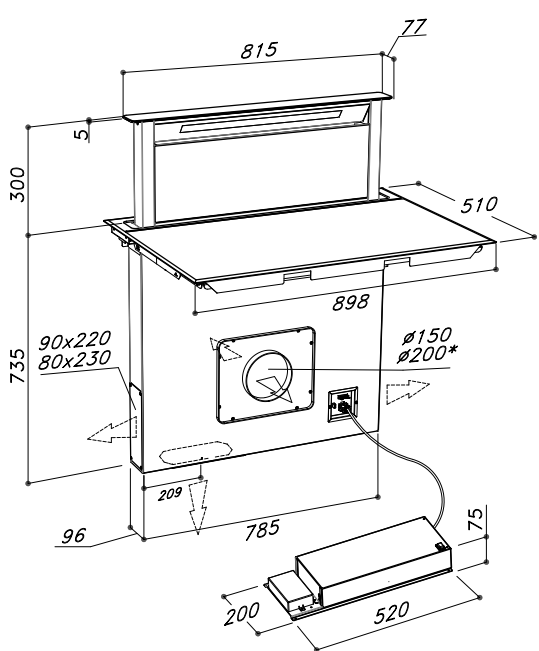

* accessory outlet $\varnothing 200\text{mm}$
 Apertura top: 860x490 mm
 Rectangular opening: 860x490mm

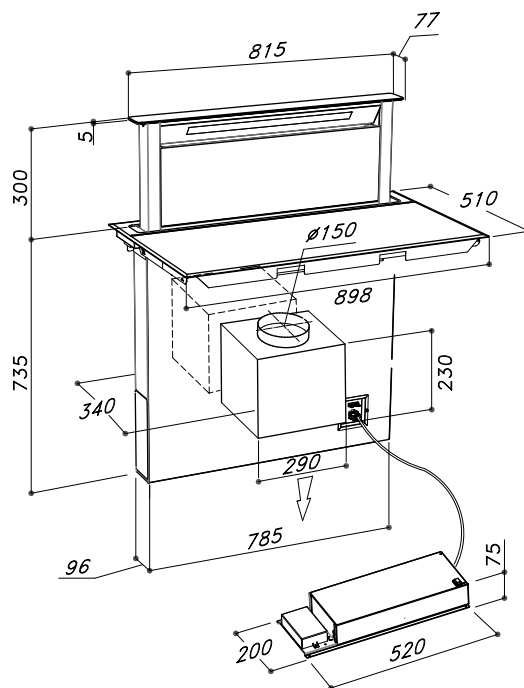

Apertura top: 860x490 mm
 Rectangular opening: 860x490mm

Motor Type	EEL CLASS	AEEchood (KWh/a)	FDE CLASS	LE CLASS	GFE CLASS	dB(A) BOOST speed	Qmax (mc/h) 50	W
on-board	A	44,5	A	A	E	68	757	1x5
SEM1	B	54,5	A	A	E	59	682	1x5
SEM2	C	82,9	C	A	E	62	731	1x5
SEM8	C	102,6	B	A	F	64	753	1x5
SEM10	C	54,3	C	A	E	61	530	1x5
SEM12	B	65,2	A	A	E	68	668	1x5



S - DDH1

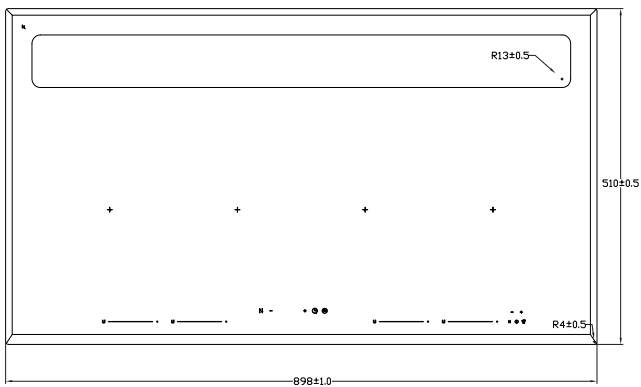

S - DDH2

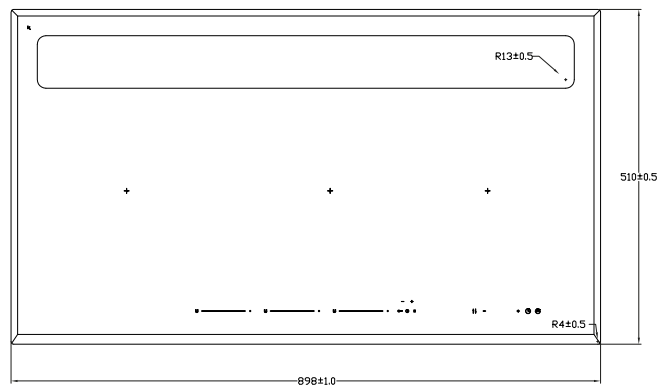



Sirius
● ○ ●

Zona Ind.le Berbentina 6/a
60041 SASSOFERRATO (An)
tel. 0732.97171 fax. 0732.95493
siriuscappe@siriuscappe.com

www.siriuscappe.com