

# Freestanding French Door Refrigerator Freezer, 79cm, 487L

Series 7 | Contemporary

Black Stainless Steel | French hinge



Designed for those who need plenty of flexible space for their cold and frozen food storage.

- ActiveSmart™ technology helps keep food fresher for longer by constantly maintaining the ideal temperature.
- Spacious bottom freezer with full extension drawer gives easy access to frozen goods.

## DIMENSIONS

Height	1715mm
Width	790mm
Depth	695mm

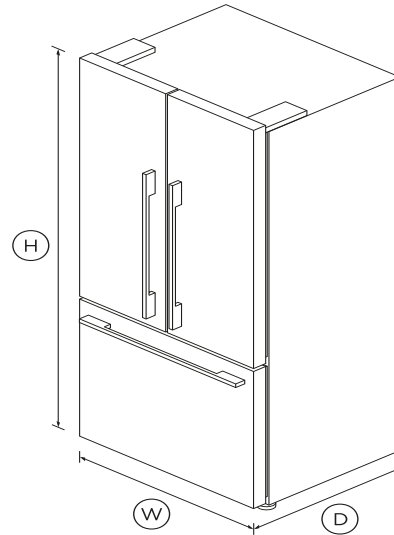

## FEATURES & BENEFITS

### Clever energy

Your refrigerator adapts to daily use by cooling and defrosting only when needed. This means it uses only the energy it needs without compromising on food care.

### Easy to clean

No more permanent dirty marks with our EZKleen feature for stainless steel refrigerators. Anti-fingerprint coating means you simply wipe clean any marks. Spill-safe secure glass shelves easily capture any drips or leaks.

### Design quality

Our refrigerators are designed and built using quality materials. We use real stainless steel, and solid glass for shelving as well as in our wine cabinet doors.

### Humidity control

Your fruit and veges need different environments. The humidity control slides in each storage bin create a microclimate that helps keep food fresher for longer.

## SPECIFICATIONS

### Capacity

Total net volume	487L
Volume freezer	142L
Volume refrigerator	345L

### Consumption

Energy consumption	361kWh/year
Energy rating	F

### Features

Adjustable door shelves	6
Adjustable glass shelves	3
Covered door shelves	2
Door alarm	•
Fruit and vegetable bins	2
LED lighting	•
SmartTouch control panel	•
Stackable bottle holders	4

### Freezer Features

Bottle chill	•
Door alarm	•
Fast freeze	•
Ice bin and scoop	•
Large plastic bins	•

The product dimensions and specifications in this page apply to the specific product and model. Under our policy of continuous improvement, these dimensions and specifications may change at any time. You should therefore check with Fisher & Paykel's Customer Care Centre to ensure this page correctly describes the model currently available. © Fisher & Paykel Appliances Ltd 2020



**A PEACE OF MIND SALE**

**24 Hours 7 Days a Week Customer Support**

**T 08000 886 605 W [www.fisherpaykel.com](http://www.fisherpaykel.com)**

### Performance

ActiveSmart™ technology	•
Adaptive defrost	•
Frost free freezer	•
Humidity control system	•
Inverter controlled compressor	•
Noise emissions	<b>42dBA</b>
Noise emissions class	<b>D</b>
Sabbath mode	•

### Power requirements

Supply voltage	<b>220 - 240V</b>
----------------	-------------------

### Product dimensions

Depth	<b>695mm</b>
Height	<b>1715mm</b>
Width	<b>790mm</b>

### Warranty

Parts and labour	<b>5 years</b>
------------------	----------------

SKU	<b>26402</b>
-----	--------------