



Norcool – Cave 20 BU Dual Zone

Cave 20 BU is a small and elegant wine cooler that can be integrated under your kitchen worktop. As with its built-in sister model, dual zone technology allows you to select your required temperature between 6°C to 18°C, covering the spectrum of perfect drinking temperatures for red, white and rosé wine.

Cave 20 BU has been awarded the German Plus X Award for quality and design.



Product benefits:

- Capacity for approx. 16 standard 75 cl wine bottles
- High quality oak shelves trimmed with an aluminum profile
- LED lighting and automatic light dimming when the door is opened or closed
- Ultra Violet resistant door glass to provide protection against harmful effects of the sun on the wine
- Electronic display
- Two independent storage zones, they can be regulated between 6-18 °C
- Low energy consumption (Energy class A+)

Technical Information on Norcool - Cave 20 BU Dual Zone



Energy consumption: 84,63 kWh/year (A+)



Capacity: Approx. 16 standard 75 cl wine bottles



Lighting: Light emitting diodes (LED)



Thermostat setting: 6-18 °C



For Integration: Yes



Weight: 32 kg net

Exterior dimensions:	W295 x H845-905 x D567 mm, plus adapter
Niche dimensions:	W300 x H845 (min) x D580mm
Door frame:	Natural anodized aluminum
Shelves:	2 high quality wooden oak and aluminum shelves
Capacity:	Approx. 16 standard 75 cl. wine bottles
Cooling compartments:	Dual zone
Thermostat setting:	6-18°C upper zone and 6-18°C lower zone
Control type:	Digital electronic control
Display:	LCD screen with white back light
Control panel:	Touch buttons
Alarm:	Audio alarm when the door is kept open to long
Ambient temperature:	10- 27 °C
Weight:	Net 32 kg
Defrosting:	Automatic
Insulation:	CFC- free polyuretan foam
Door glass:	Tinted safety glass with UV protection
Lighting:	Light emittion diodes (LED)
LED color:	White
Door hanging:	Order right or left hinged
Handle:	Natural anodized aluminum
Cold production:	Compressor
Coolant:	R- 600 A
Volt/ hz:	220-240V AC 50 Hz
Noise level:	38 dba
Energy consumption:	85,63 kWh/year (Energy class A+)
Air circulation:	Fan
Ventilation requirements:	70 cm2 integrated in the product
Power extension cord:	2,7 m

Technical drawing of Norcool Cave 20 BU

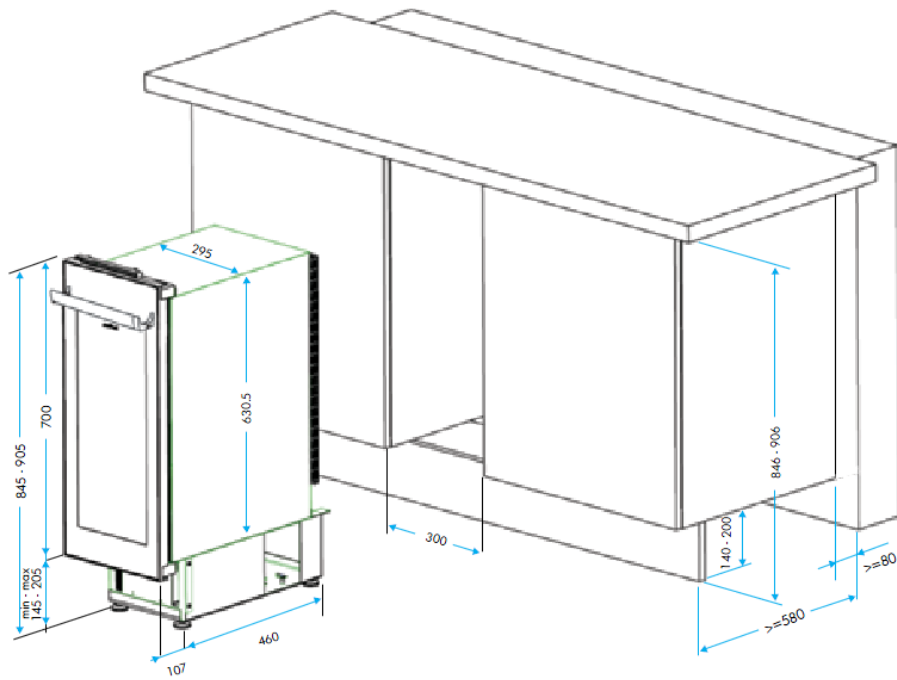

Cave 20 BU Right hinged
Cave 20 BU Left hinged

Product number: 12670005
Product number: 12670014